



GENUINE PARTS

INSTALLATION INSTRUCTIONS

DESCRIPTION: Rear Bumper Protector

APPLICATION: Nissan Pathfinder

PART NUMBER: 999T6 XZ000

KIT CONTENTS:

Item	Qty.	Part Description
A	1	Rear Bumper Protector
B	2	Spacers
C	1	Installation Instruction Replacement Template

TOOLS REQUIRED:

- Clean, Lint-Free Wiping Cloth
- 90% (or greater) Isopropyl Alcohol
- Scale
- Masking Tape

PRE-INSTALLATION WARNINGS, CAUTIONS, CRITICAL STEPS, and NOTES:

- Dealer installation recommended. Instructions may refer to Service Manual.

CAUTION

- Please wash vehicle with soap and water prior to installing bumper protector.
- Do not wash vehicle for 24 hours after installing bumper protector.
NOTE: Washing vehicle less than 24 hours after installing bumper protector could cause it to not adhere properly.
- Install bumper protector only when part and vehicle temperature are between 16°C - 43°C (60°F - 110°F).
- Failure to clean mounting surface properly may cause tape to have poor adhesion to vehicle.
- Failure to apply enough pressure to all of tape may cause bumper protector to not adhere properly.
- To allow time for adhesive to cure, maintain vehicle temperature between 16°C - 43°C (60°F - 110°F) for a minimum of 2 hours after installing bumper protector.

INSTALLATION PROCEDURE:

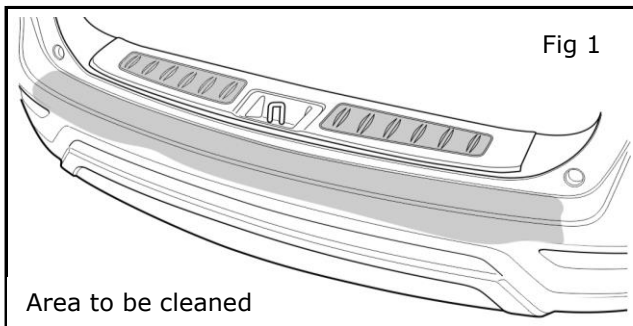

- 1) Clean vehicle attachment area thoroughly with soap and water to remove any dirt or debris and allow time to dry.
- 2) Bumper protector installation prep.
 - a) Open rear hatch.
 - b) Using a clean lint-free cloth and 90% isopropyl alcohol, clean area of rear bumper where part will be installed.
 - c) Allow time to dry thoroughly. (Fig 1)

NOTE: Failure to clean mounting surface properly may cause tape to have poor adhesion to vehicle.

INSTALLATION PROCEDURE:

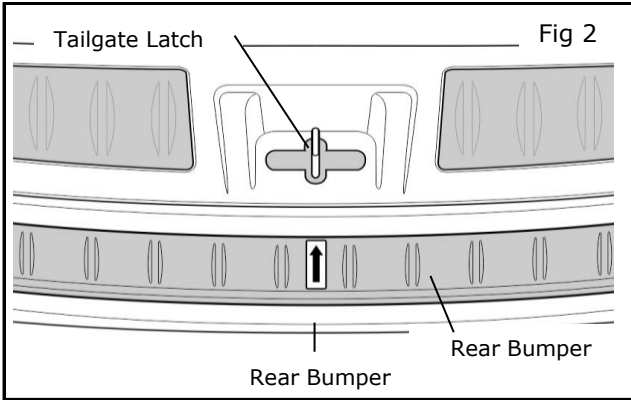

- 3) Dry fit bumper protector on vehicle by aligning bumper protector centering arrow with tailgate latch. (Fig 2)

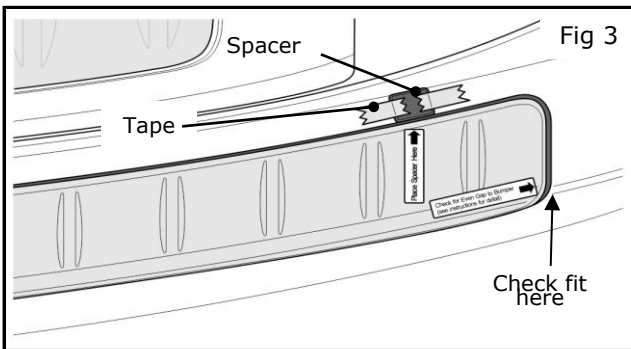

- 4) Position spacer block at label locations on both sides of vehicle. Spacer block should fit tight between part and bumper. (Fig 3)
- 5) Peel back protective film near spacer blocks.
- 6) Secure spacer block to bumper with masking tape. (Fig 3)
- 7) Check fore/aft alignment of bumper protector to curvature of bumper for consistent gap. (Fig 3)

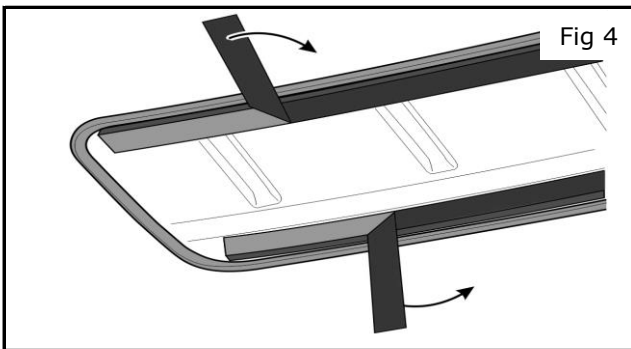

- 8) Prepare tape. (Fig 4)
 - a) Remove part.
 - b) Peel back approximately 30mm (1¼in) on all tape liners.
 - c) Fold back all liners.

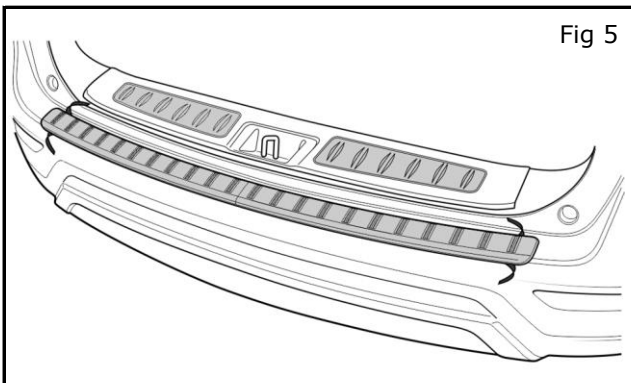

- 9) Re-align part to vehicle and lightly tack bumper protector to vehicle. (Fig 5)
- 10) Confirm center arrow alignment to vehicle and tight fit to spacers. If necessary, un-tack bumper protector and repeat. (Fig 5)

INSTALLATION PROCEDURE:

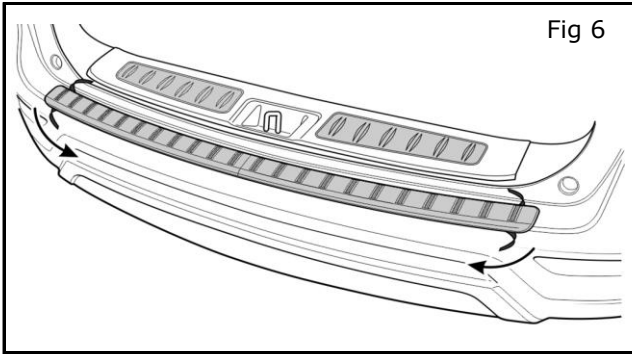

11) While holding the part in position, with one hand at center arrow, remove rear tape liners. (Fig 6)

12) Using a clean lint-free cloth, start at center and apply 1 kg/cm^2 (15 lbs/in^2) of firm pressure along tape path.

13) Remove spacer blocks.

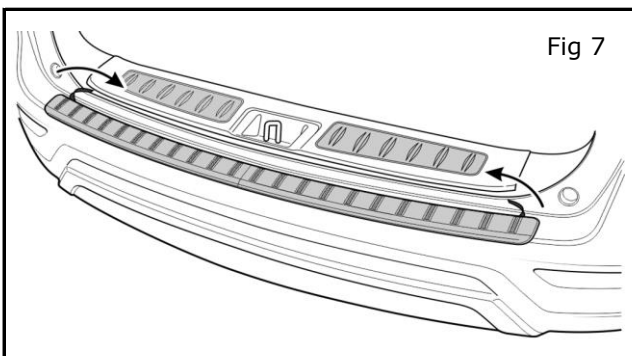

14) Remove front tape liners. (Fig 7)

NOTE: Gently pull up on front edge of part as you pull front tape liners so they do not break.

15) Using a clean lint-free cloth, start at center and apply 1 kg/cm^2 (15 lbs/in^2) of firm pressure along tape path.

16) To ensure adequate adhesion, re-apply 1 kg/cm^2 (15 lbs/in^2) of firm pressure across entire part.
NOTE: Failure to apply enough pressure to all of tape may cause bumper protector to not adhere properly.

17) Remove protective film from part.

18) Close rear hatch.

19) Maintain vehicle temperature between 16°C - 43°C (60°F - 110°F) for a minimum of 2 hours, and do not expose vehicle to moisture for a minimum of 24 hours. This will allow time for tape to cure.